



Sicherheit
Safety



Montage
Mounting



Bedienung
Handling



Stückliste
Bill of material

UDAPTION®

Stand-Series

U-Stand
6100-0001



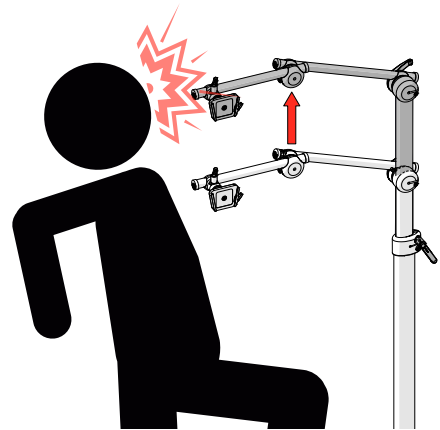
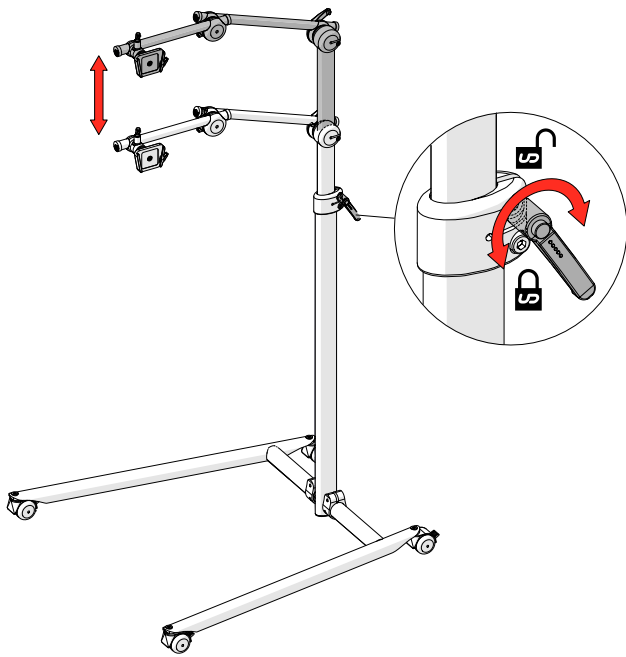
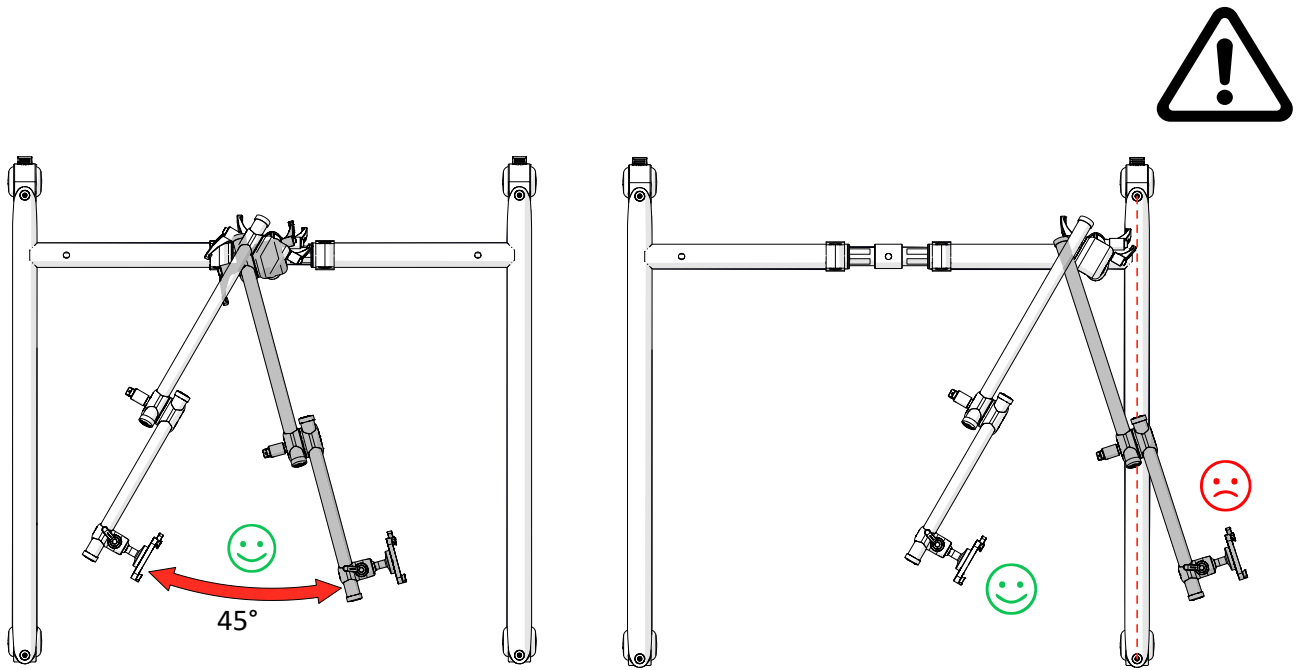

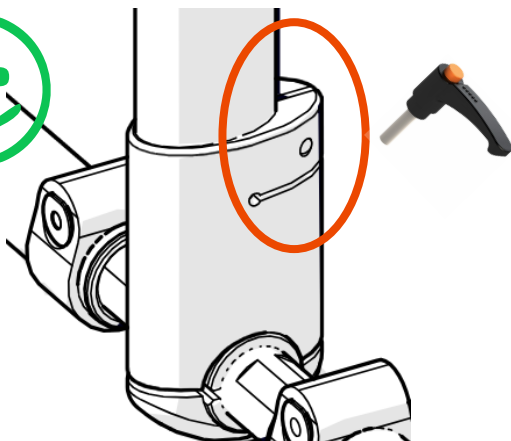
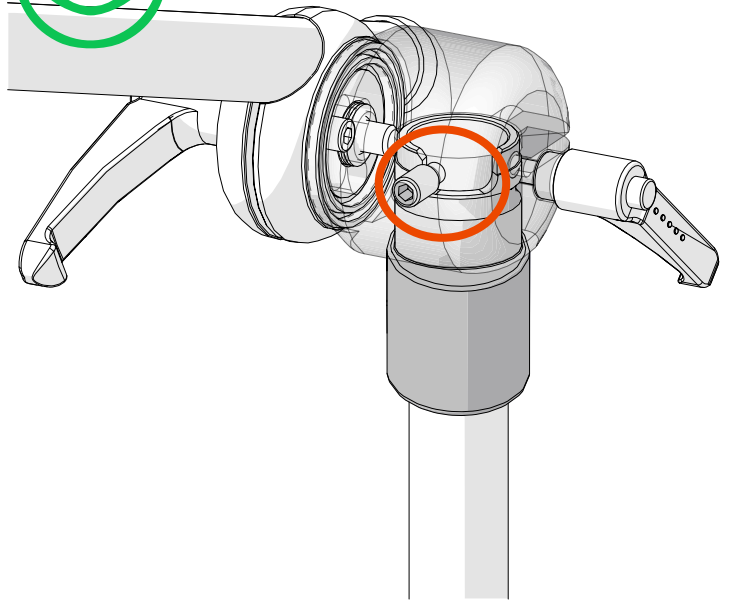
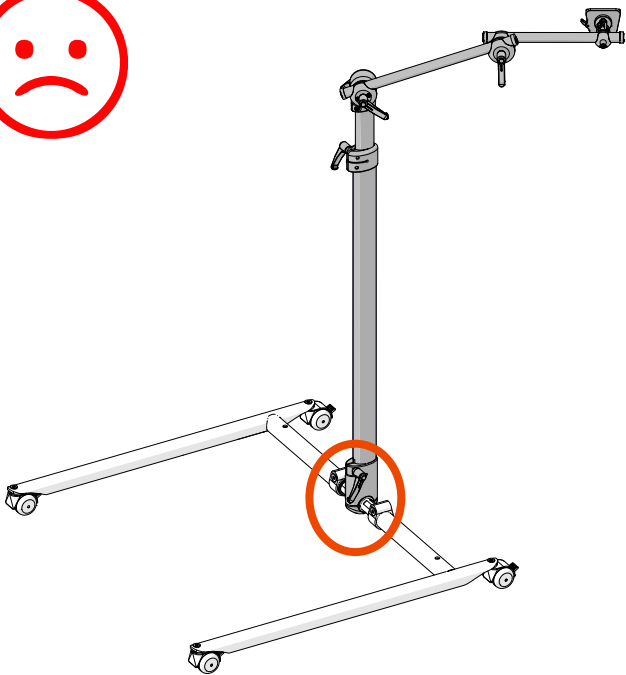
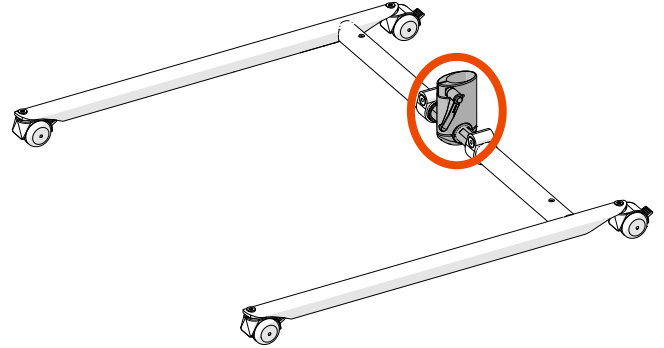
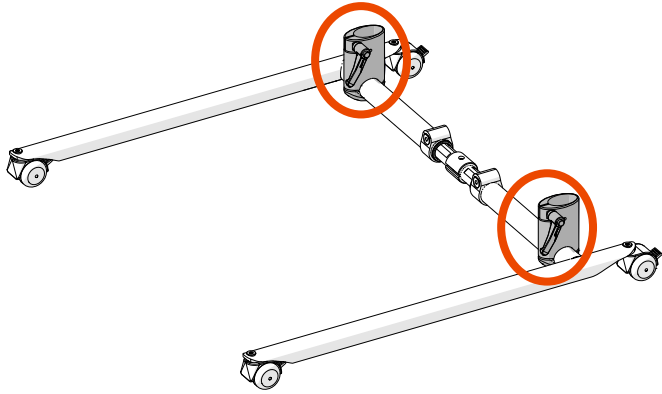

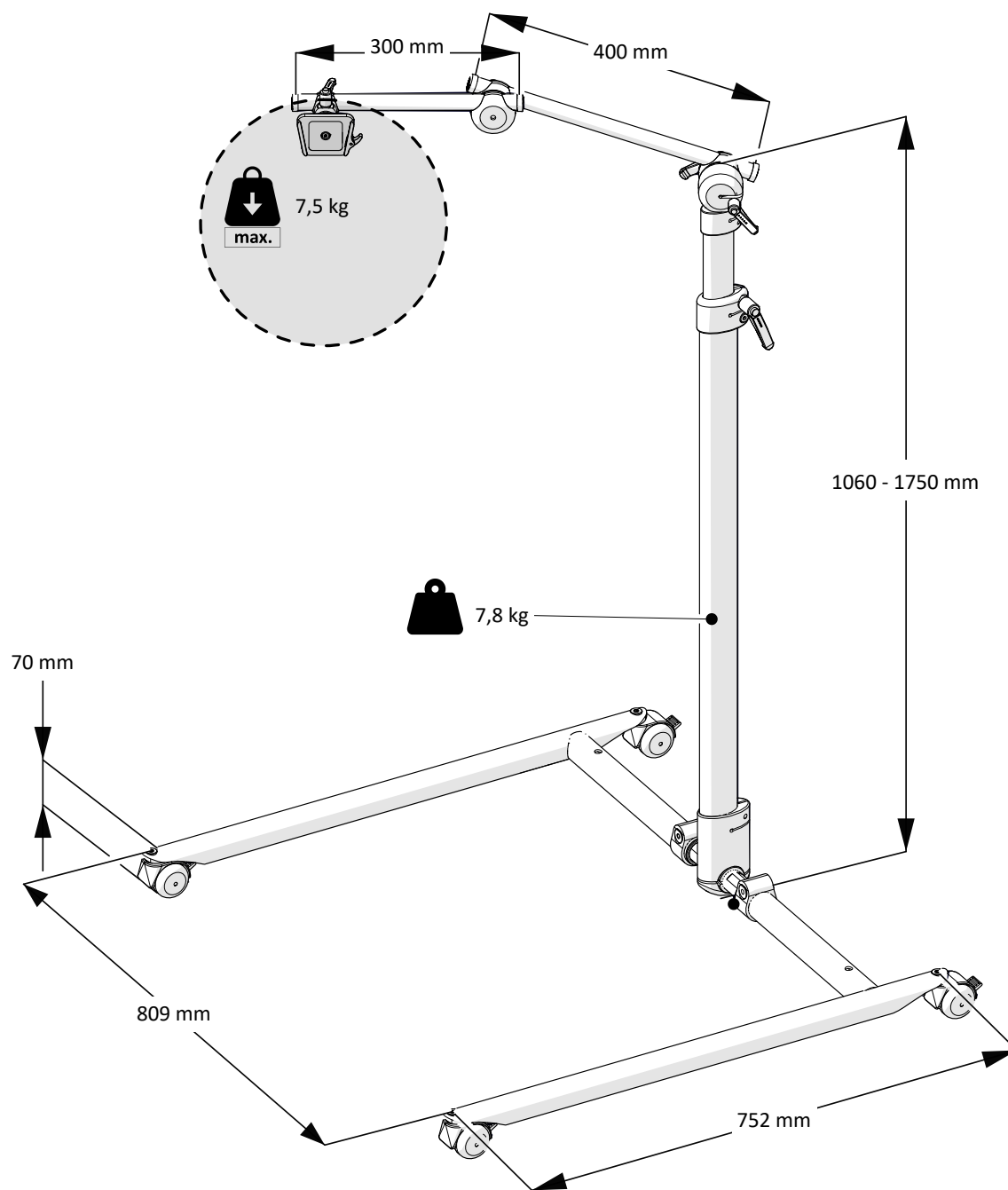

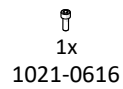
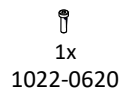
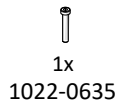
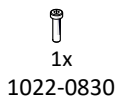
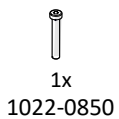
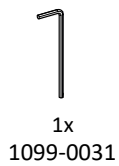
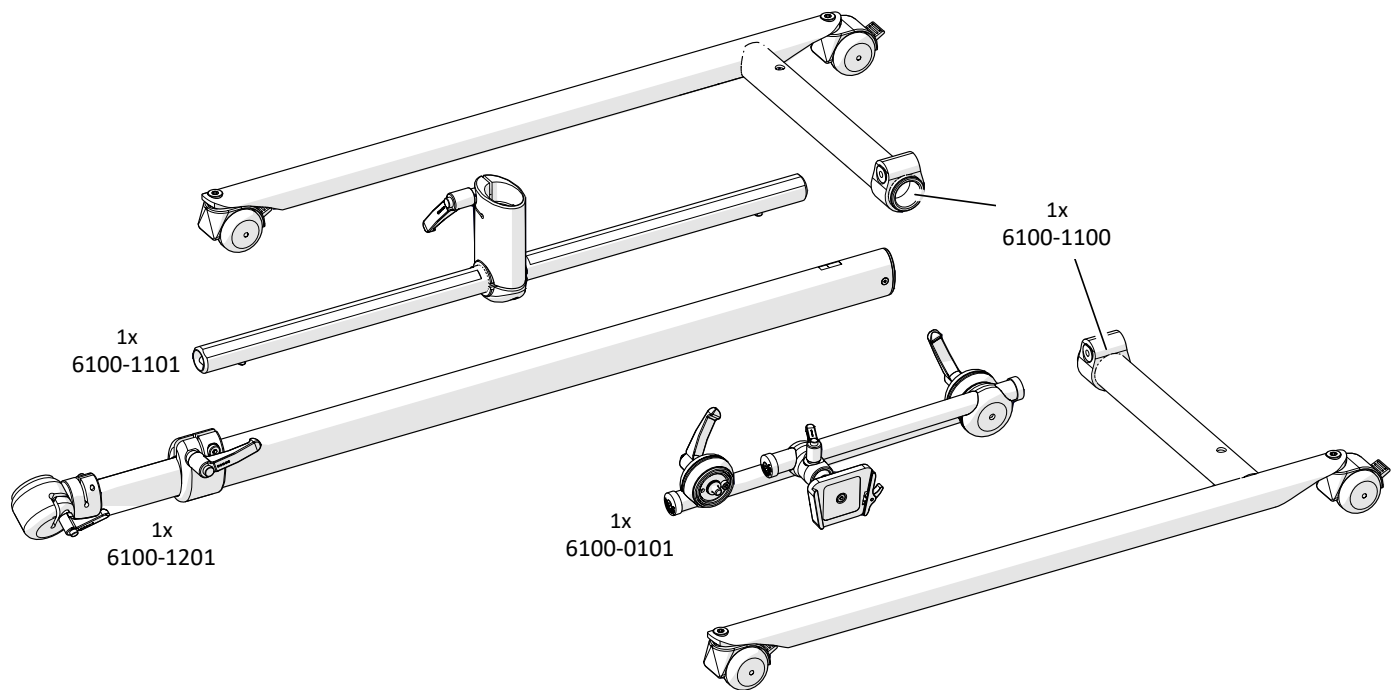

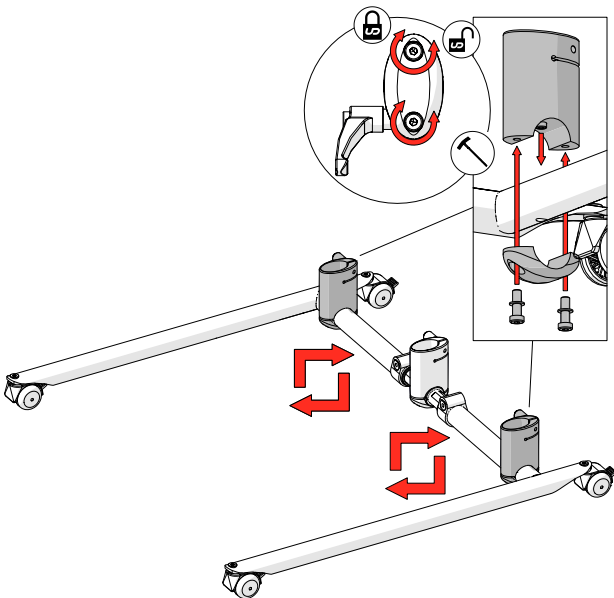
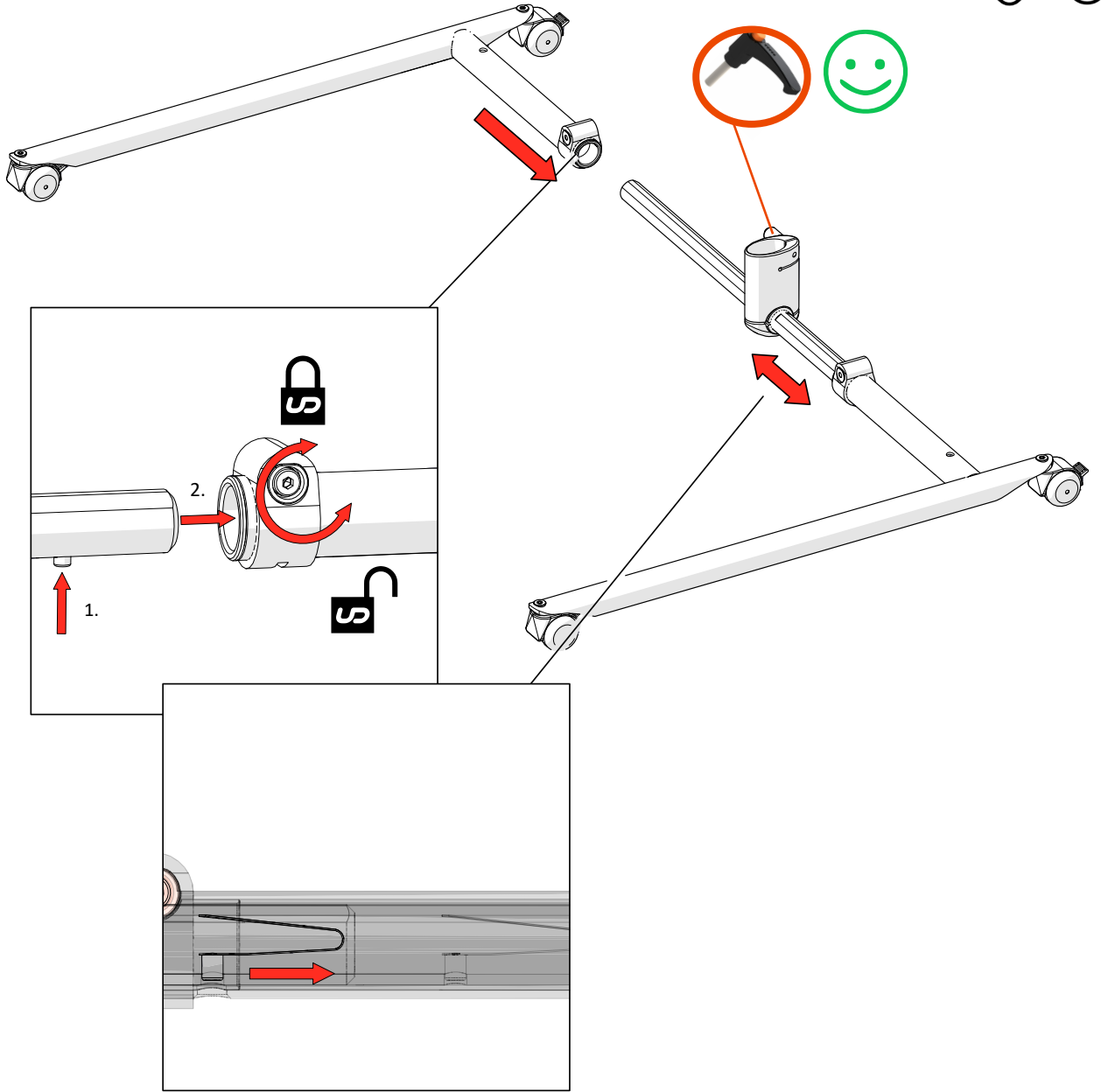

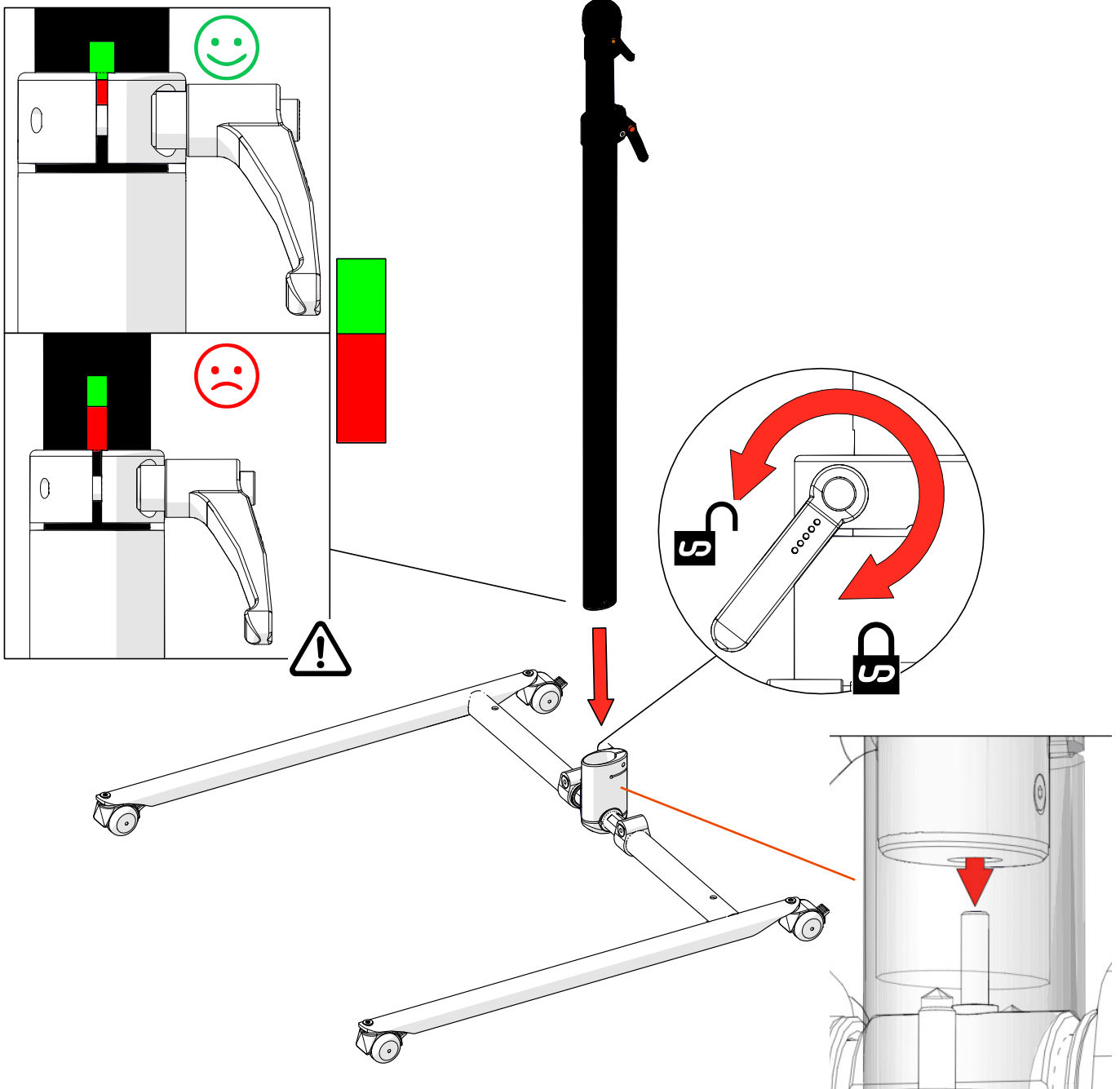

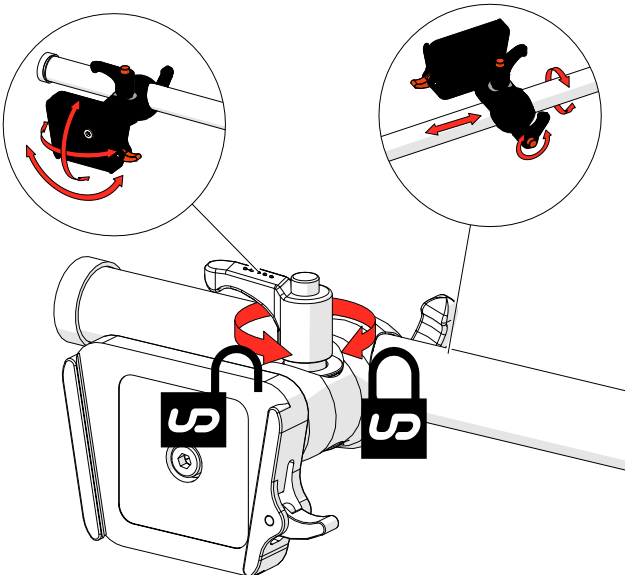
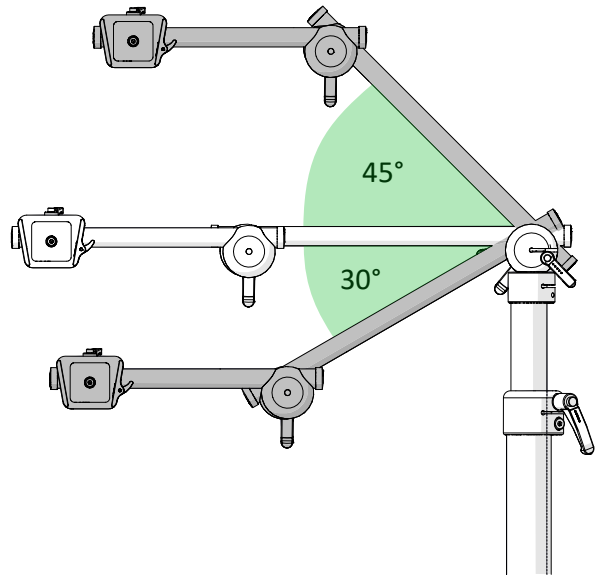
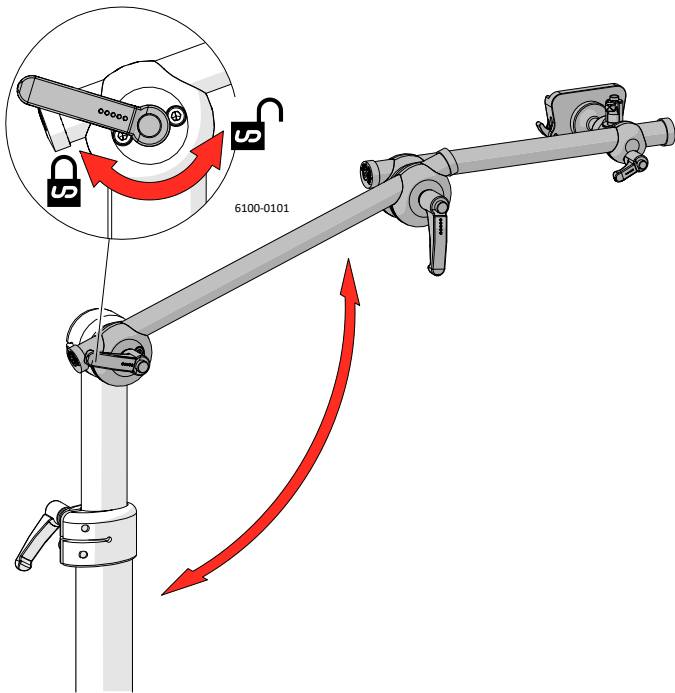
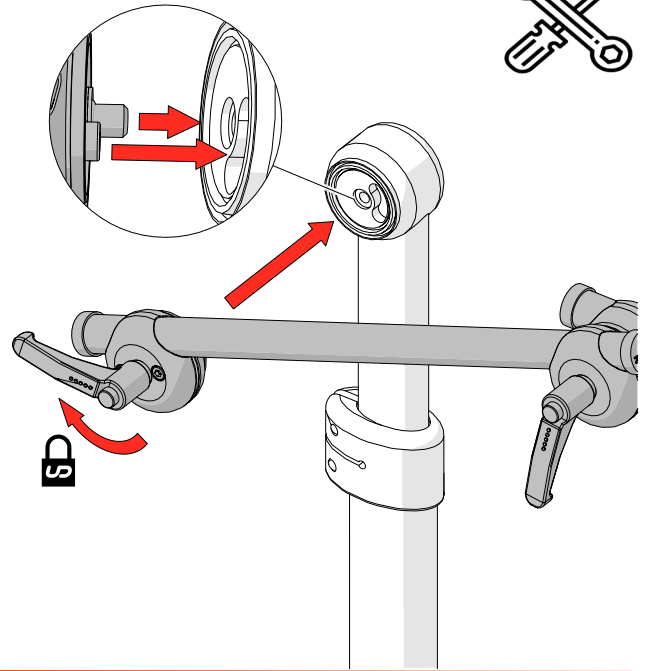
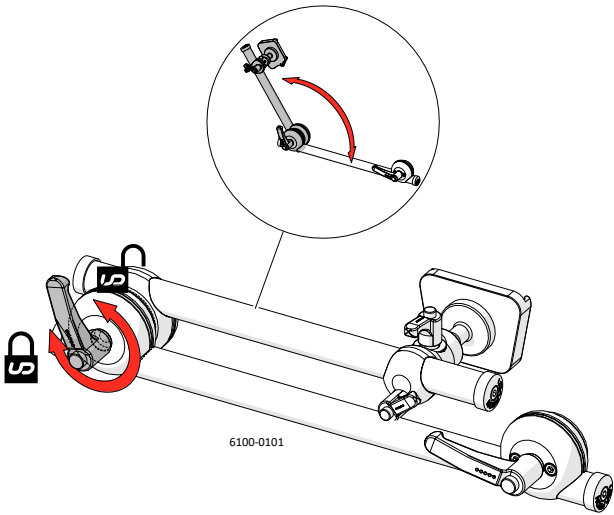

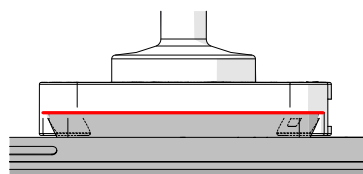
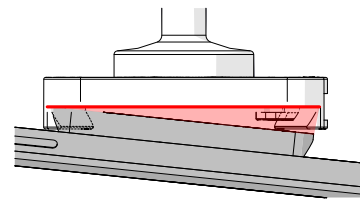
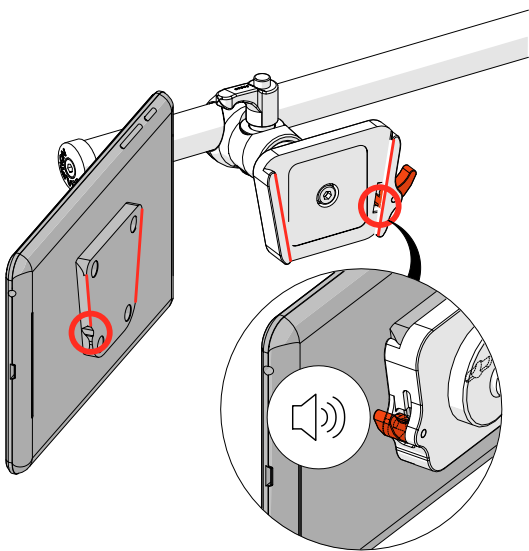
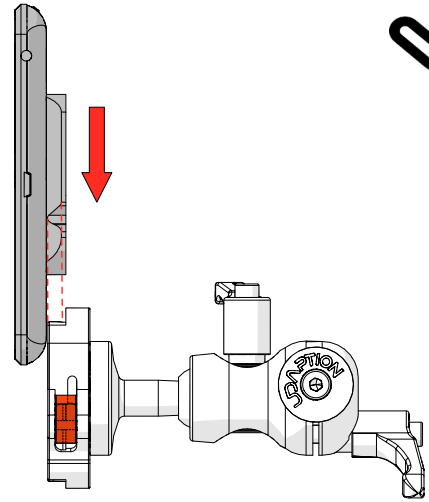
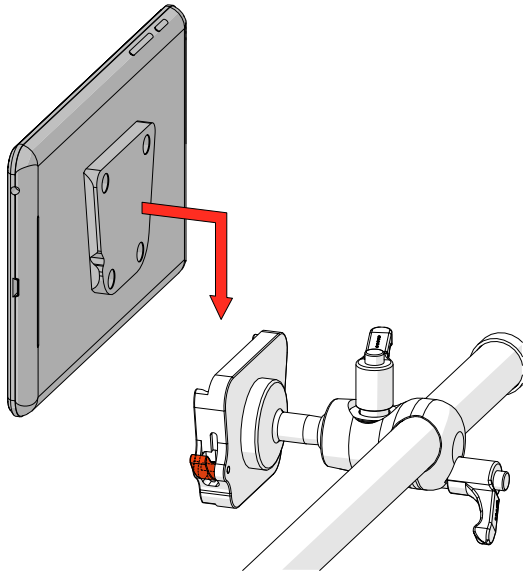

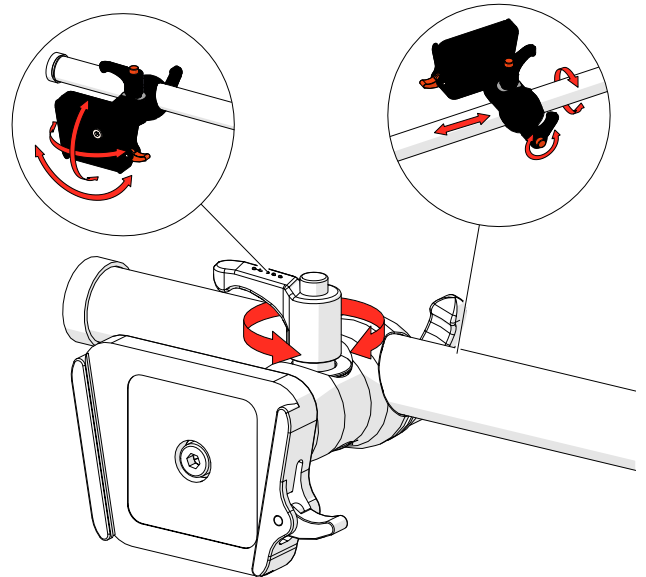
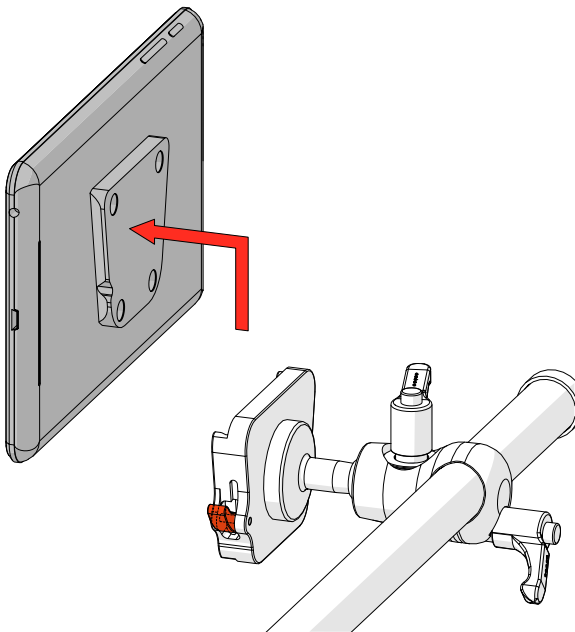
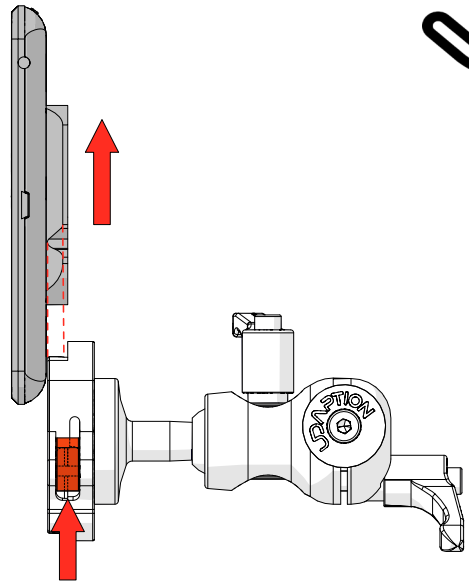
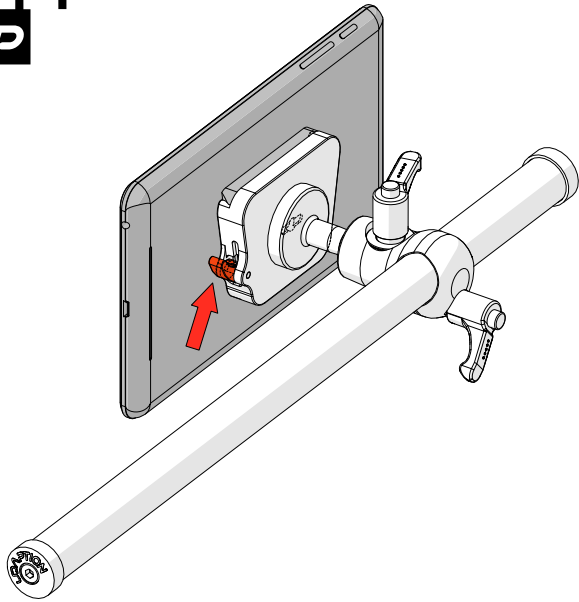

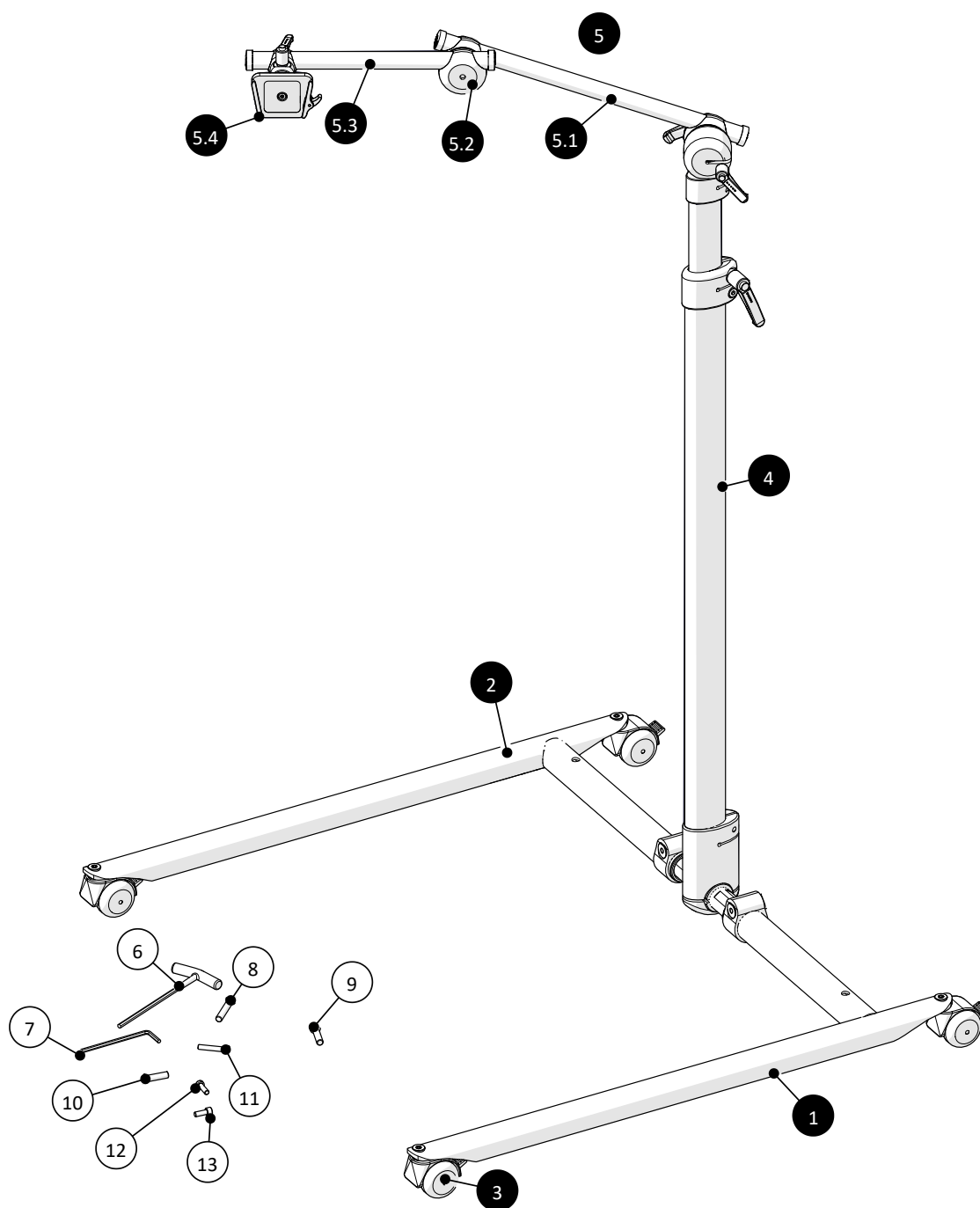



Pos.	Art. No.	Beschreibung / Description	Qty.
1	6100-1110	Seitenstrebe links / Side strut left	1
2	6100-1120	Seitenstrebe rechts / Side strut right	1
3	1241-0008	Doppelrolle mit Bremse Ø 50mm / Swivel caster Ø 50mm	4
4	6100-1201	Vertikalstütze U-Stand / Vertical support U-Stand	1
5	6100-0101	Horizontalhalterung 22 / Horizontal mount 22	1
5.1	6110-2242	AL-Rundrohr Ø22X2X400 sw.eloxiert mit Abrutschsicherung Aluminium tube 22X2X400 black anodized with anti slip protection	1
5.2	6105-1101	Standard Rohrgelenk 22 / Standard joint 22mm	1
5.3	6110-2232	AL-Rundrohr Ø22X2X300 sw.eloxiert mit Abrutschsicherung Aluminium tube 22X2X300 black anodized with anti slip protection	1
5.4	6180-0001	UDA-1B-22	1
6	1099-0039	5mm T-Griff Imbus / 5mm T-Handle Allen key	1
7	1099-0031	4mm Sechskantschlüssel / 4mm Allen key	
8	1022-0850	Zylinderschraube M8X50 / Cylinder head bolt M8X50 (7984)	1
9	1022-0835	Zylinderschraube M8X35 / Cylinder head bolt M8X35	1
10	1022-0830	Zylinderschraube M8X30 / Cylinder head bolt M8X30	1
11	1022-0635	Zylinderschraube M6X35 / Cylinder head bolt M6X35	1
12	1021-0625	Zylinderschraube M6X25 / Cylinder head bolt M6X25	1
13	1022-0616	Zylinderschraube M6X16 / Cylinder head bolt M6X16	1



1121-0835-DOR

1121-0835-DBL

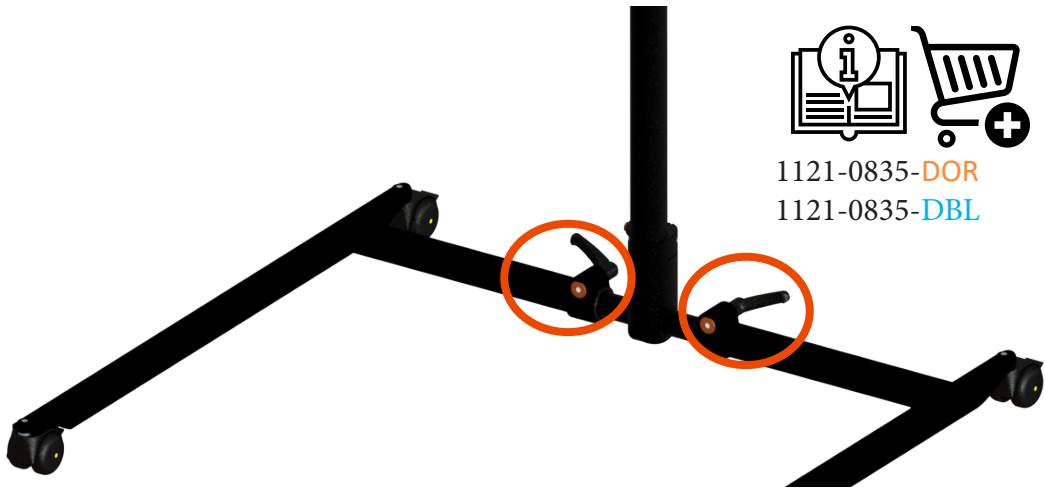



Beachten Sie zusätzlich das Dokument „Allgemeine Sicherheits- und Warnhinweise für „Stand-Series“
Beachten Sie zusätzlich das Dokument „Reinigungs- und Desinfektionsrichtlinien“



Please also note the document “General safety and warning information for „Stand-Series“
Please also note the document “Cleaning and Disinfection Guidelines”



Veillez également noter le document « Informations générales de sécurité et d'avertissement pour „Stand-Series“
Veillez également noter le document « Consignes de nettoyage et de désinfection »



Si prega di leggere anche il documento “Informazioni generali sulla sicurezza e avvertenze per il „Stand-Series“
Si prega di prendere visione anche del documento “Linee guida per la pulizia e la disinfezione”



Tenga en cuenta también el documento “Información general de seguridad y advertencias para „Stand-Series“
Tenga en cuenta también el documento „Pautas de limpieza y desinfección“.



Observe também o documento “Informações gerais de segurança e aviso para „Stand-Series“
Observe também o documento “Diretrizes de Limpeza e Desinfecção”



Kérjük, vegye figyelembe az „Általános biztonsági és figyelmeztető utasítások az „Stand-Series“ című dokumentumot is.
Kérjük, vegye figyelembe a „Tisztítási és fertőtlenítési irányelvek” című dokumentumot is.



Lees ook het document “Algemene veiligheids- en waarschuwinginformatie voor „Stand-Series“
Neem ook het document “Reinigings- en desinfectierichtlijnen” in acht.



Vær også oppmerksom på dokumentet „Generell sikkerhets- og advarselsinformasjon for „Stand-Series“
Vær også oppmerksom på dokumentet „Retningslinjer for rengjøring og desinfeksjon



Bemærk også dokumentet „Generel sikkerheds- og advarselsinformation for „Stand-Series“
Bemærk også dokumentet „Rengørings- og desinfektionsretningslinjer“



Observera även dokumentet „Allmän säkerhets- och varningsinformation för „Stand-Series“
Observera också dokumentet „Rengörings- och desinfektionsriktlinjer“



Huomioi myös asiakirja „Yleiset turvallisuus- ja varoitukset „Stand-Series“
Huomioi myös asiakirja „Puhdistus- ja desinfiointiohjeet“

INSORS® GMBH



Struthof 2
55595 Münchwald / Germany



+49 6706 915 1630



+49 6706 915 1640



udaption@insors.de



www.udaption.com

